

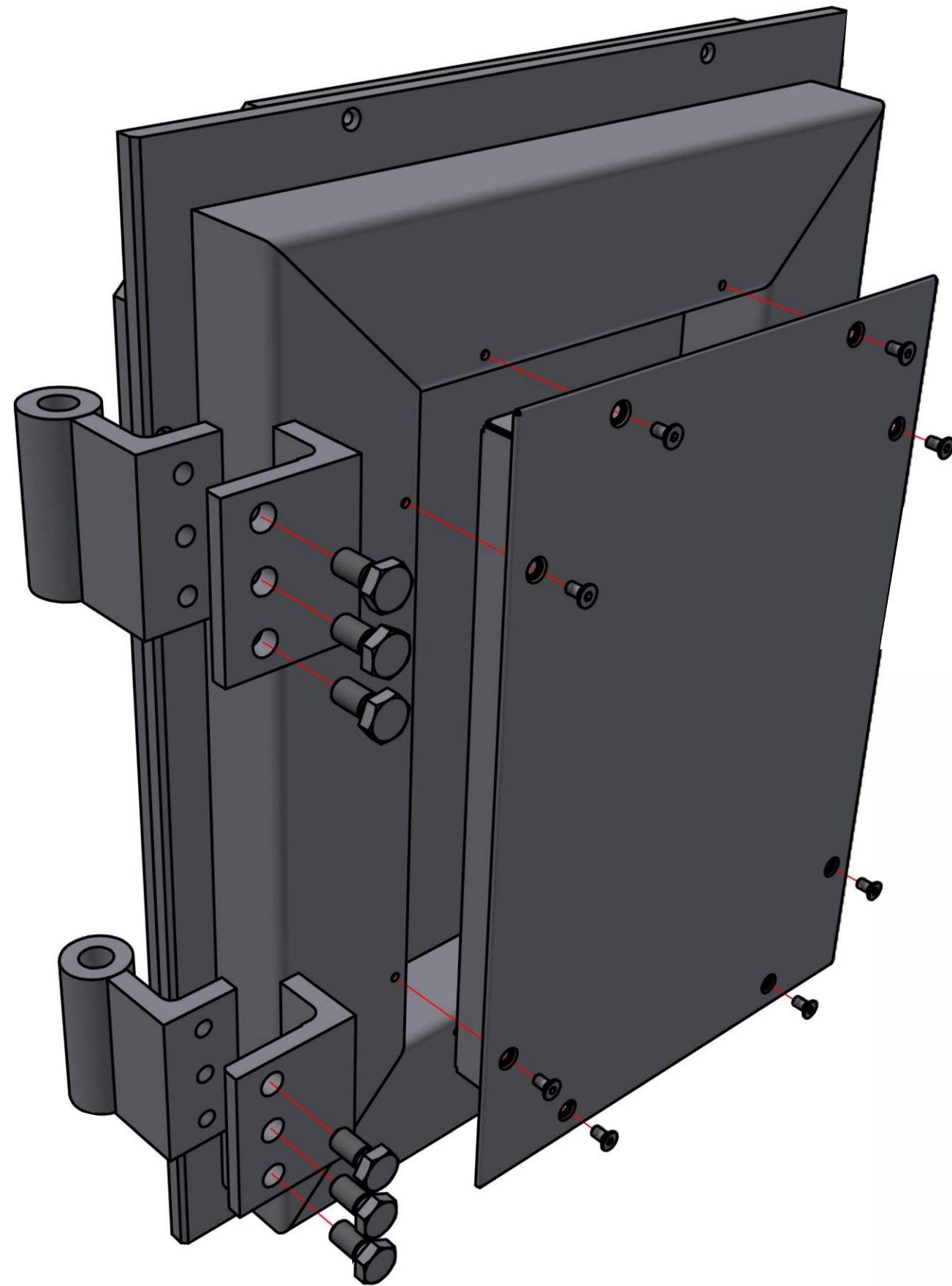

Gez.			Meisterarbeit Fahrzeugbau	
Gepr.				
Norm gepr.				
Maßstab	Bezeichnung:	Panzertür 1		
1: 5				
Allgemein- toleranzen	Zusammenbau			



Gez.	Datum	Name	Meisterarbeit Fahrzeugbau	
Gepr.				
Norm gepr.				
Maßstab	Bezeichnung:		Türl komplett	
1: 2				
Allgemein- toleranzen	Panzertür 1			