

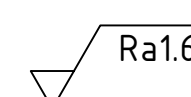

 Ra1.6  Fasengröße 1x45°
Kantenbruch -0,3
XXX=Kennnummer

 Ra1.6  Fasengröße nicht bemaßte Kanten 1x45°
Kantenbruch -0,3
XXX=Kennnummer

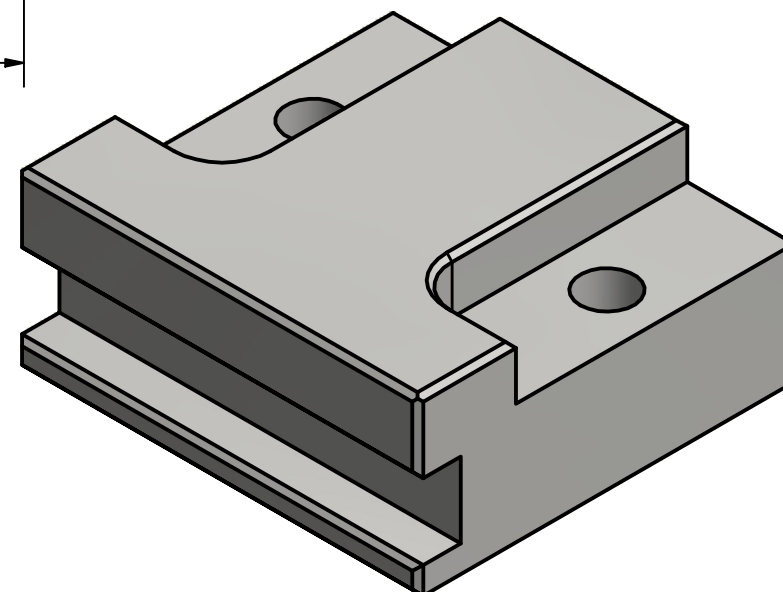
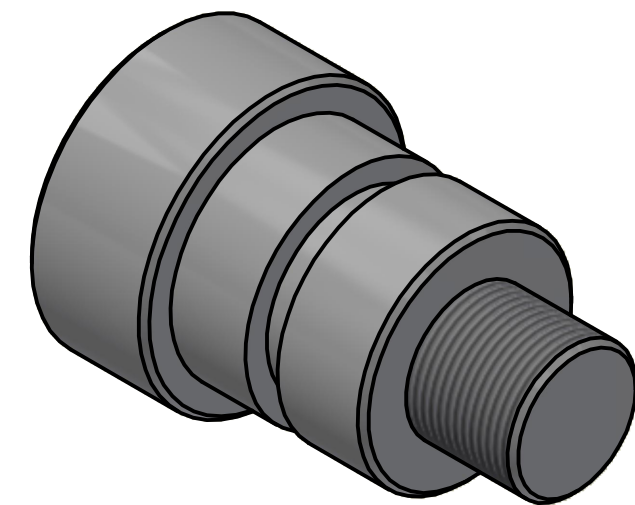
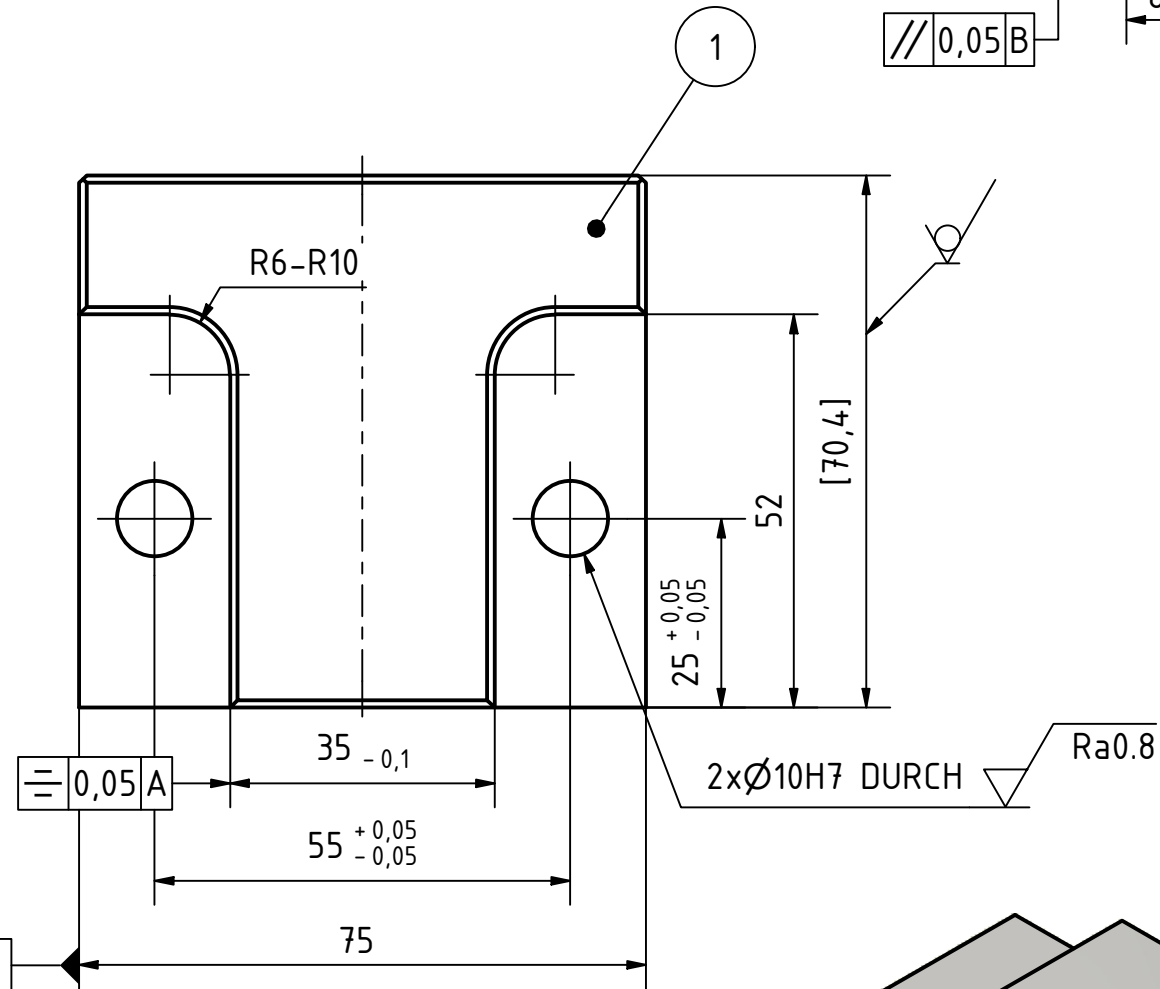
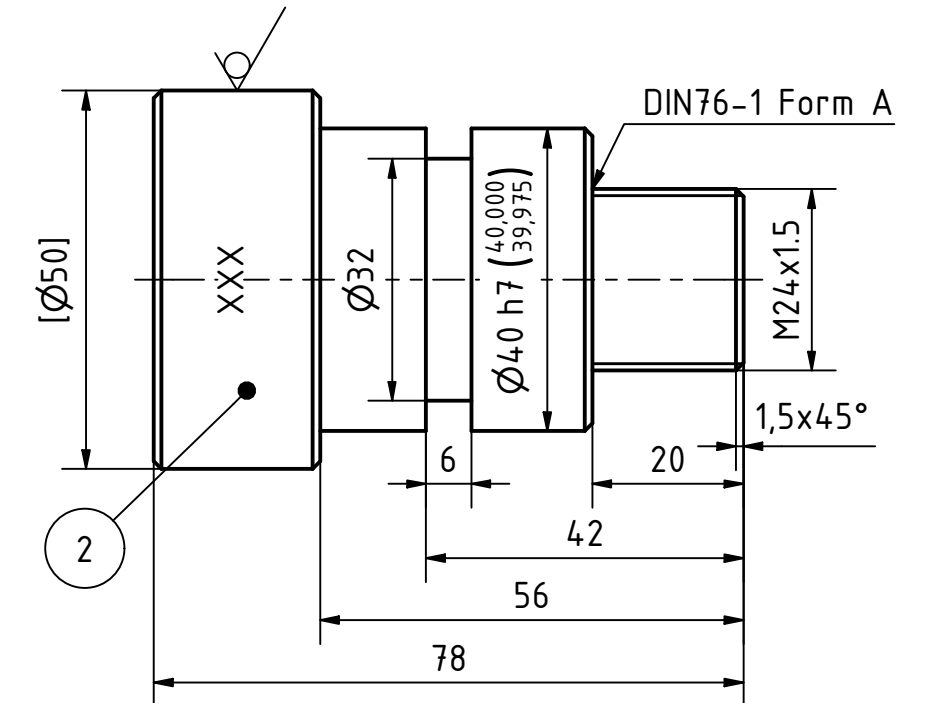
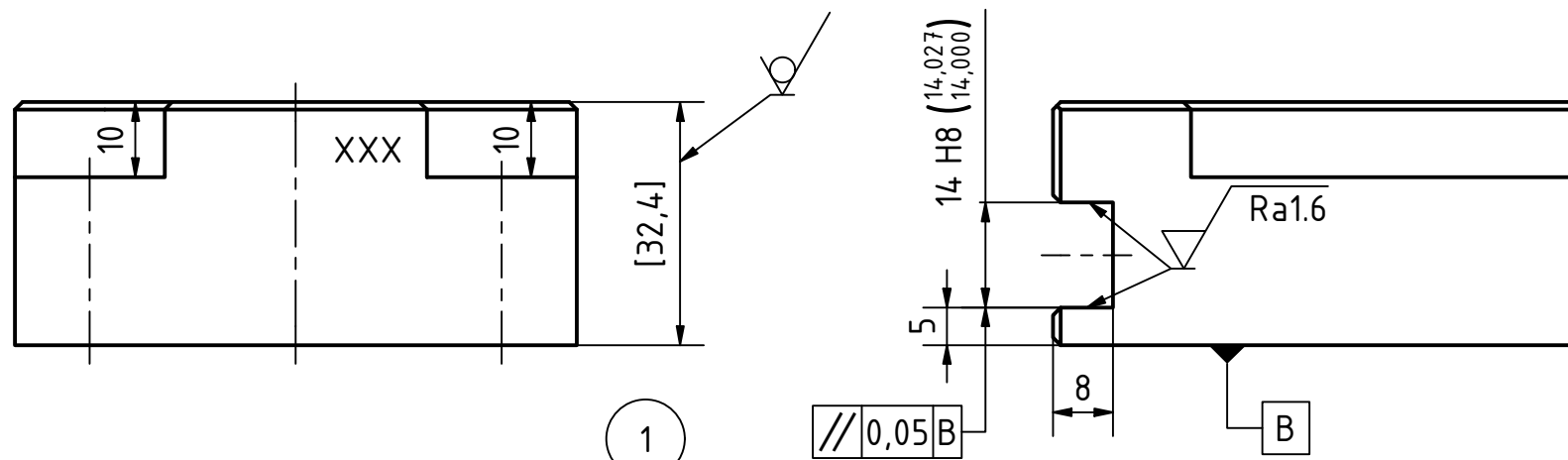
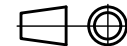

Pos	Stk	Benennung	Material	Norm	Rohmaße	Bemerkung
2	1	KV Drehen	1.0718		Ø50x88	
1	1	KV Fräsen	1.0037		32,4x70,4x78	

	Kandidat:		LWB 3.Lehrjahr MBT				
	Kennnummer:		Projekt:Konventionell Fräsen - Drehen				
	Datum		Bauteil:				
	Name		Baugruppe:				
Gezeichnet	24.03.2014	MG	Projektion	Maßstab	Position:	Werkstoff:	Blatt
Allgemeintoleranz ISO 2768-mH Werkstückkanten ISO 13715 Oberflächen DIN ISO 1302 Form und Lagetoleranz DIN ISO 1101				1:1	Stück:	Rohmaß:	1/1
EDV Nummer: F:\01.Metallwerkstätten\Prüfungsservice\LWB\2026\MBT 3LJ. neu.dwg							